

## C.I. SQUARE TYPE DOUBLE SEAL MANHOLE COVER & FRAME AS PER BS 497/1976

Light, Medium & Heavy Duty ❖ Test Load : 10KN, 150KN & 350KN - Block dia. 300mm.

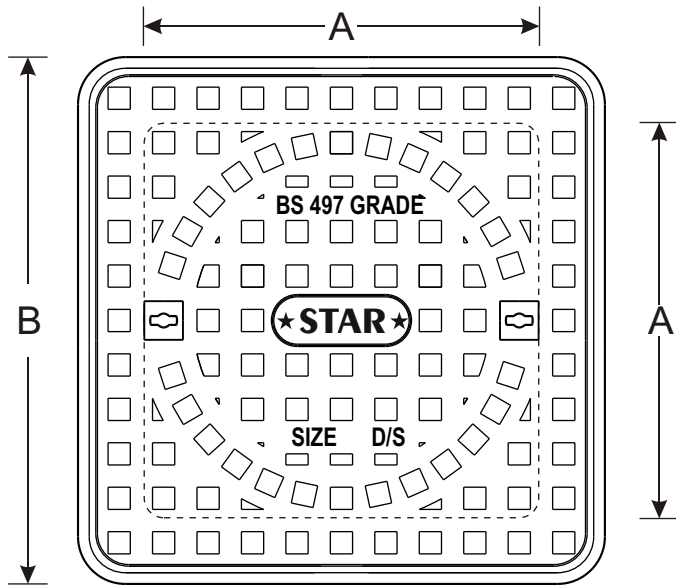

TOP VIEW OF COVER

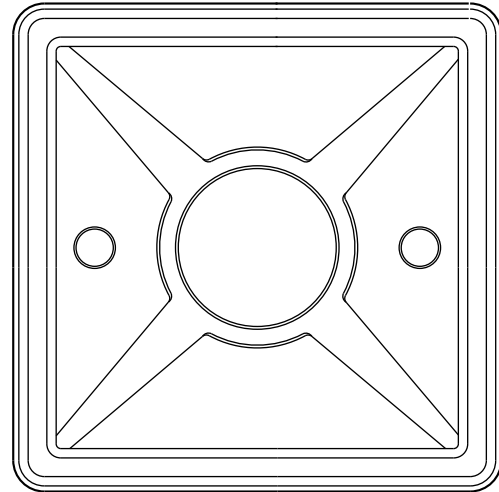

BOTTOM VIEW OF COVER

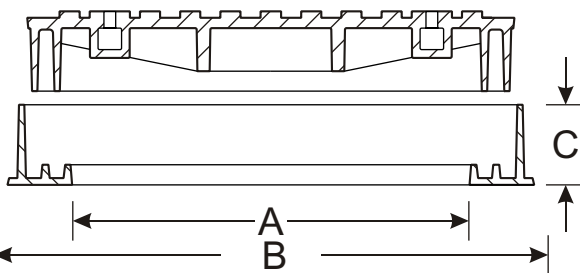

SECTIONAL VIEW OF COVER & FRAME

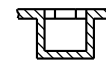
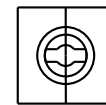

KEY-HOLE SECTION

Sr. No.	B.S. Ref.	Clear Opening of frame mm. A x A	Over Base of frame mm. B x B	Height of frame mm. C	Weight (Kgs.)	TYPE
10	-	300 X 300	380 X 380	42	15 Kgs	Double Seal Solid Top Cover & Frame L/D
11	MC2 45/45	450 X 450	580 X 580	45	38 Kgs	Double Seal Solid Top Cover & Frame L/D
12	MC2 45/45	450 X 450	590 X 590	50	50 Kgs	Double Seal Solid Top Cover & Frame M/D
13	MC2 60/60	600 X 600	750 X 750	42	45 Kgs	Double Seal Solid Top Cover & Frame L/D
14	MC2 60/60	600 X 600	750 X 750	45	50 Kgs	Double Seal Solid Top Cover & Frame L/D
15	MC2 60/60	600 X 600	750 X 750	45	55 Kgs	Double Seal Solid Top Cover & Frame L/D
16	MC2 60/60	600 X 600	750 X 750	50	60 Kgs	Double Seal Solid Top Cover & Frame L/D
17	MC2 60/60	600 X 600	750 X 750	50	75 Kgs	Double Seal Solid Top Cover & Frame L/D
18	MC2 60/60	600 X 600	750 X 750	75	80 Kgs	Double Seal Solid Top Cover & Frame L/D
19	MC2 60/60	600 X 600	750 X 750	75	85 Kgs	Double Seal Solid Top Cover & Frame L/D
20	MC2 60/60	600 X 600	750 X 750	75	95 Kgs	Double Seal Solid Top Cover & Frame L/D
21	MC2 60/45	600 X 450	710 X 560	42	50 Kgs	Double Seal Solid Top Cover & Frame L/D
22	MB2 45/45	450 X 450	620 X 620	75	70 Kgs	Double Seal Solid Top Cover & Frame M/D Gr. B
23	MB2 60/60	600 X 600	750 X 750	75	110 Kgs	Double Seal Solid Top Cover & Frame M/D Gr. B
24	MB2 60/60	600 X 600	750 X 750	75	115 Kgs	Double Seal Solid Top Cover & Frame M/D Gr. B
25	MB2 60/60	600 X 600	780 X 780	80	150 Kgs	Double Seal Solid Top Cover & Frame M/D Gr. B
26	A2	600 X 600	785 X 785	100	190 Kgs	Double Seal Solid Top Cover & Frame H/D Gr. A
27	A2	600 X 600	790 X 790	100	210 Kgs	Double Seal Solid Top Cover & Frame H/D Gr. A
28	A	600 X 600	800 X 800	125	250 Kgs	Double Seal Solid Top Cover & Frame H/D Gr. A

drawn by : H. Vyas

date : 01/01/2006

approved by : Rosy

date : 01/01/2005

www.starpipelineindia.com

scale : NTS

revision : 007

date : 01/01/2021

## CAST IRON SQUARE TYPE SINGLE SEAL MANHOLE COVER & FRAME

Light, Medium & Heavy Duty As Per BS 497/1976  
Test Load : 10KN, 150KN & 350KN - Block dia. 300mm.

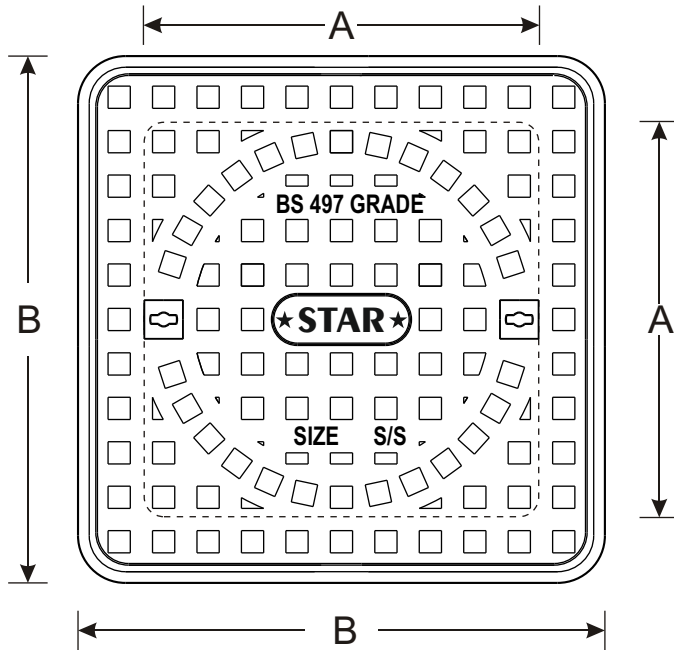

TOP VIEW OF COVER

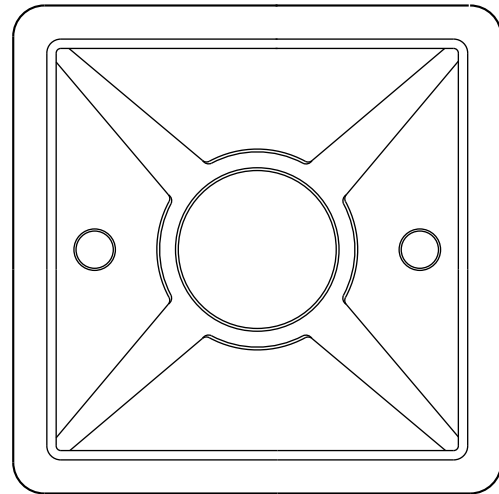

BOTTOM VIEW OF COVER

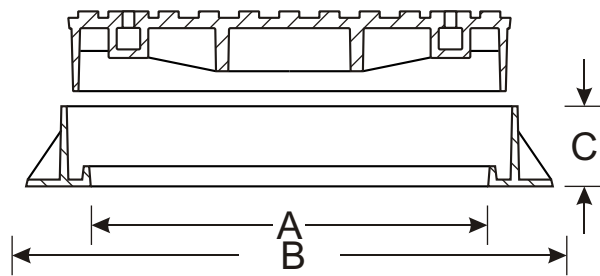

SECTIONAL VIEW OF COVER & FRAME

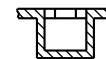
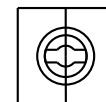

KEY-HOLE SECTION

Sr. No.	B.S. Ref.	Clear Opening of frame mm. A x A	Over Base of frame mm. B x B	Height of frame mm. C	Weight (Kgs.)	TYPE
1	-	250 X 250	300 X 300	20	4 Kgs	Single Seal Solid Top Square Cover & Frame
2	-	300 X 300	340 X 340	20	5 Kgs	Single Seal Solid Top Square Cover & Frame
3	-	300 X 300	350 X 350	25	7 Kgs	Single Seal Solid Top Square Cover & Frame
4	-	300 X 300	375 X 375	42	13 Kgs	Single Seal Solid Top Square Cover & Frame
5	-	300 X 300	380 X 380	42	16 Kgs	Single Seal Solid Top Cover & Frame L/D
6	MC1 45/45	450 X 450	530 X 530	42	25 Kgs	Single Seal Solid Top Cover & Frame L/D
7	MC1 45/45	450 X 450	530 X 530	42	28 Kgs	Single Seal Solid Top Cover & Frame L/D
8	MC1 60/60	600 X 600	690 X 690	42	34 Kgs	Single Seal Solid Top Cover & Frame L/D
9	MC1 60/45	600 X 450	700 X 550	42	32 Kgs	Single Seal Solid Top Cover & Frame L/D

drawn by : H. Vyas

date : 01/01/2006

approved by : Rosy

date : 01/01/2005

www.starpipelineindia.com

scale : NTS

revision : 007

date : 01/01/2021

## CAST IRON RECESSED TYPE MANHOLE COVER & FRAME AS PER BS 497/1976

Single Seal And Double Seal Light, Medium & Heavy Duty

Test Load : 10KN, 150KN & 350KN - Block dia. 300mm.

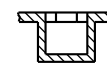
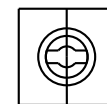
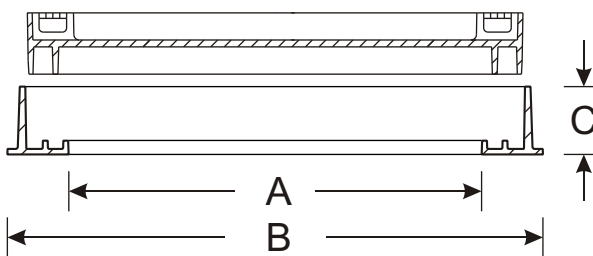
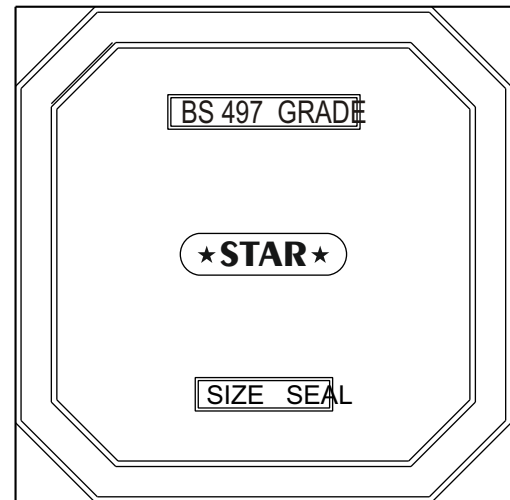
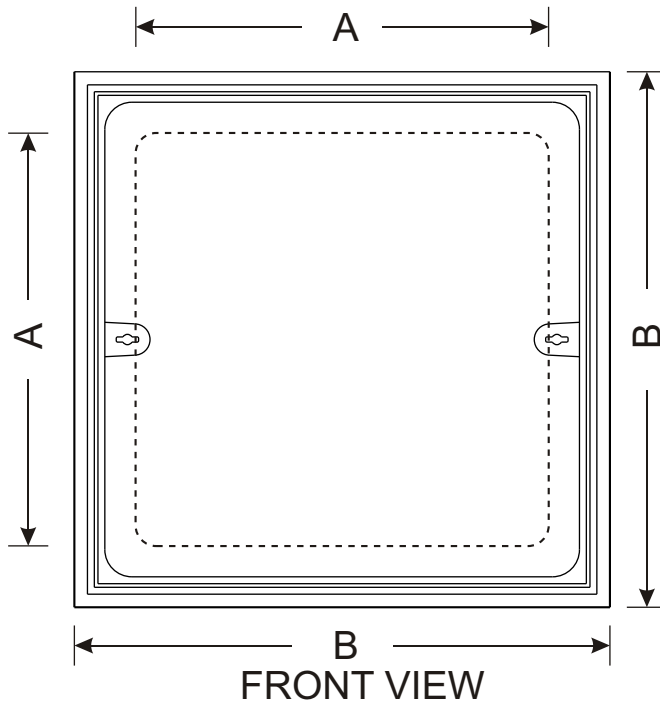

KEY-HOLE  
SECTION

Sr. No.	B.S. Ref.	Clear Opening of frame mm. A x A	Over Base of frame mm. B x B	Height of frame mm. C	Weight (Kgs.)	TYPE
29	MC2R 30/30	300 X 300	400 X 400	65	30 Kgs	Double Seal Recessed Manhole Cover & Frame L/D Gr. C
30	MC2R 30/30	300 X 300	420 X 420	110	35 Kgs	Double Seal Recessed Manhole Cover & Frame L/D Gr. C
31	MC1R 45/45	450 X 450	552 X 552	75	40 Kgs	Single Seal Recessed Manhole Cover & Frame L/D Gr. C
32	MC2R 45/45	450 X 450	580 X 580	65	60 Kgs	Double Seal Recessed Manhole Cover & Frame L/D Gr. C
33	MC2R 60/60	600 X 600	775 X 775	75	70 Kgs	Double Seal Recessed Manhole Cover & Frame L/D Gr. C
34	MC2R 60/60	600 X 600	775 X 775	100	85 Kgs	Double Seal Recessed Manhole Cover & Frame L/D Gr. C

drawn by : H. Vyas

date : 01/01/2006

approved by : Rosy

date : 01/01/2005

www.starpipelineindia.com

scale : NTS

revision : 007

date : 01/01/2021

## CAST IRON DOUBLE TRIANGULAR COVER & GRATING WITH SQUARE FRAME

Heavy Duty As per BS 497/1976  
Test Load : 350KN - Block dia. 300mm.

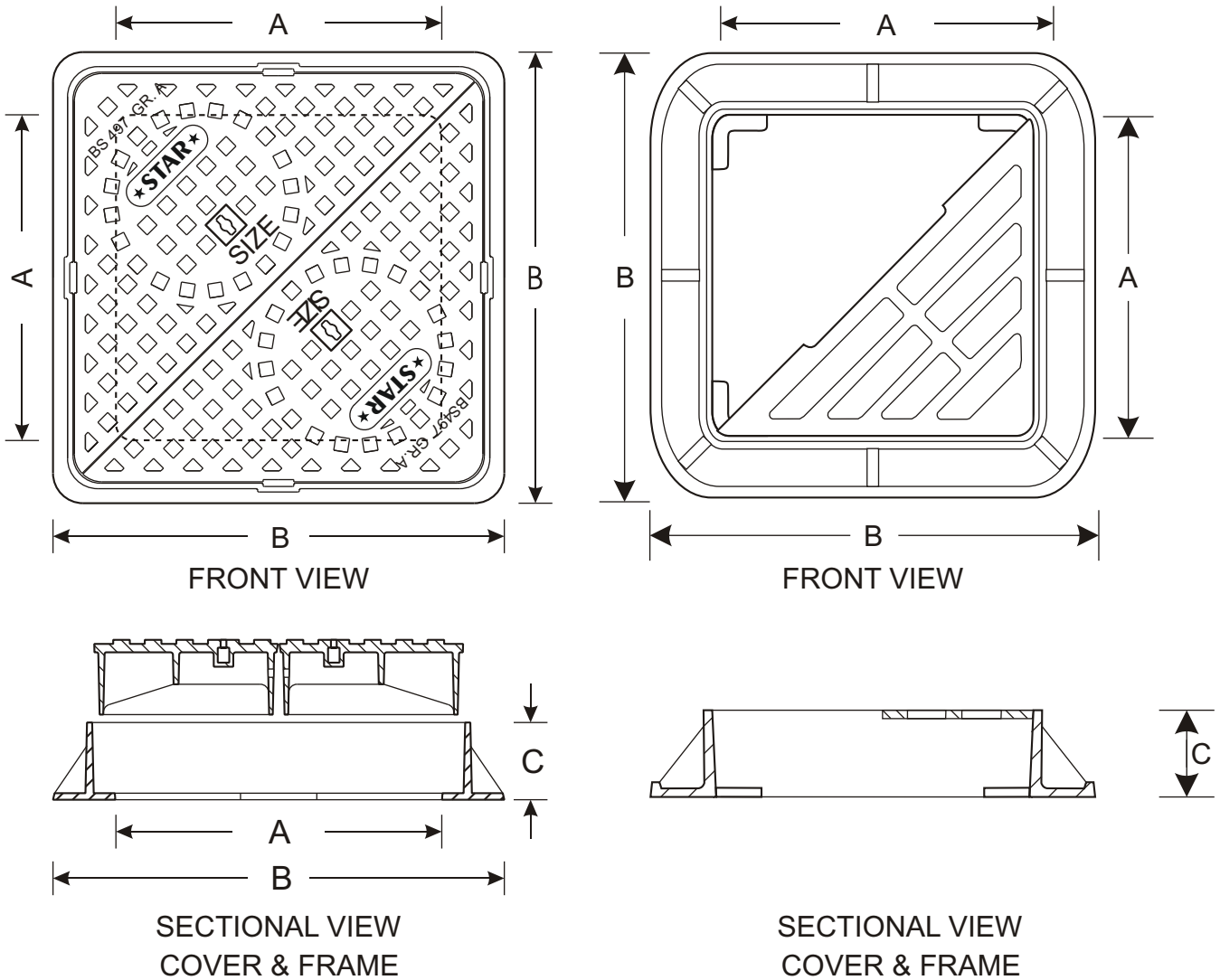

GLOBAL Ref #	B.S. Ref.	Clear Opening of frame mm. A x A	Over Base of frame mm. B x B	Height of frame mm. C	Weight (Kgs.)	TYPE
GMPC 133	MB1 60	600 X 600	750 X 750	100	145 Kgs	Double Triangular Covers with Square Frame H/D Gr. A
GMPC 134	MA 60	600 X 600	750 X 750	100	180 Kgs	Double Triangular Covers with Square Frame H/D Gr. A
GMPC 135	MA 60	600 X 600	750 X 750	150	200 Kgs	Double Triangular Covers with Square Frame H/D Gr. A
GMPC 136	GA1 450	450 X 450	600 X 600	100	90 Kgs	Double Triangular Gully Gratings & Frame H/D Gr. A
GMPC 137	GA1 450	475 X 475	625 X 550	100	95 Kgs	Double Triangular Gully Gratings & Frame H/D Gr. A
GMPC 138	-	600 X 600	750 X 750	100	180 Kgs	Double Triangular Gully Gratings & Frame H/D Gr. A

drawn by : H. Vyas

date : 01/01/2006

approved by : Rosy

date : 01/01/2005

www.starpipelineindia.com

scale : NTS

revision : 007

date : 01/01/2021

## CAST IRON DOUBLE TRIANGULAR COVER & GRATING WITH SQUARE FRAME

Heavy Duty As per BS 497/1976

Test Load : 350KN - Block dia. 300mm.

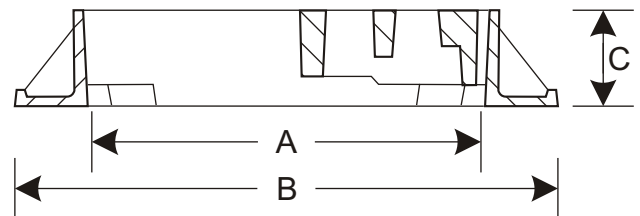
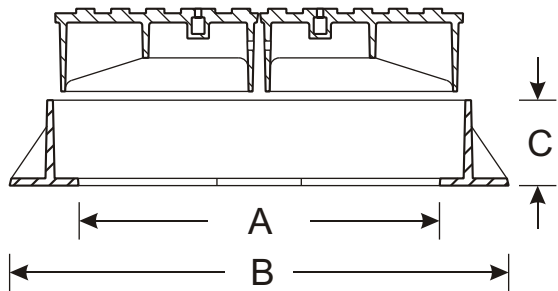
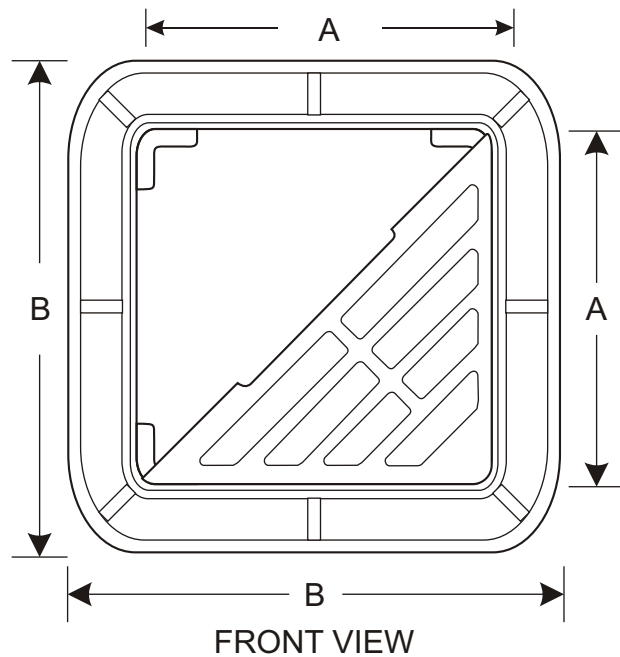
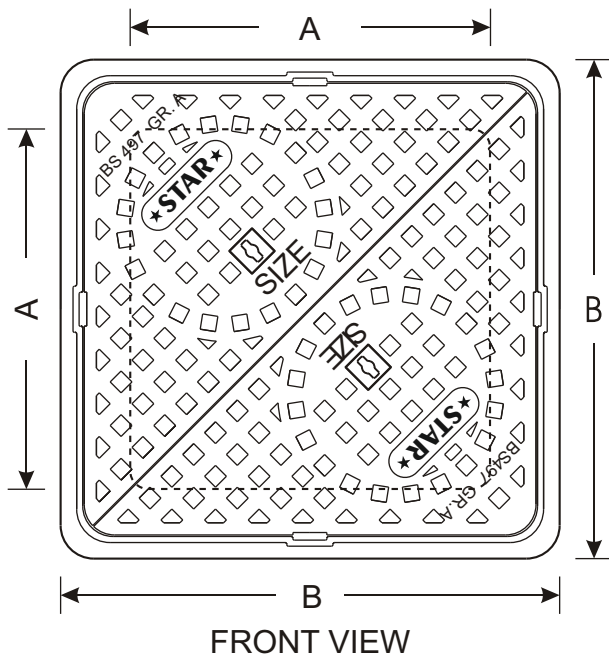

Sr. No.	B.S. Ref.	Clear Opening of frame mm. A x A	Over Base of frame mm. B x B	Height of frame mm. C	Weight (Kgs.)	TYPE
35	MB1 60	600 X 600	750 X 750	100	145 Kgs	Double Triangular Covers with Square Frame H/D Gr. A
36	MA 60	600 X 600	750 X 750	100	180 Kgs	Double Triangular Covers with Square Frame H/D Gr. A
37	MA 60	600 X 600	750 X 750	150	200 Kgs	Double Triangular Covers with Square Frame H/D Gr. A
38	GA1 450	450 X 450	600 X 600	100	90 Kgs	Double Triangular Gully Gratings & Frame H/D Gr. A
39	GA1 450	475 X 475	625 X 550	100	95 Kgs	Double Triangular Gully Gratings & Frame H/D Gr. A
40	-	600 X 600	750 X 750	100	180 Kgs	Double Triangular Gully Gratings & Frame H/D Gr. A

drawn by : H. Vyas

date : 01/01/2006

approved by : Rosy

date : 01/01/2005

www.starpipelineindia.com

scale : NTS

revision : 007

date : 01/01/2021

## CAST IRON RECTANGULAR TYPE DOUBLE SEAL MANHOLE COVER & FRAME

Light, Medium & Heavy Duty As Per BS 497/1976  
Test Load : 10KN, 150KN & 350KN - Block dia. 300mm.

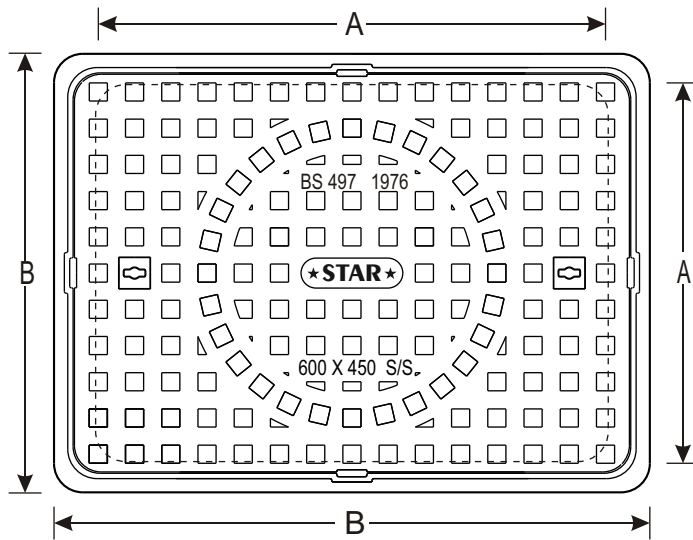

FRONT VIEW

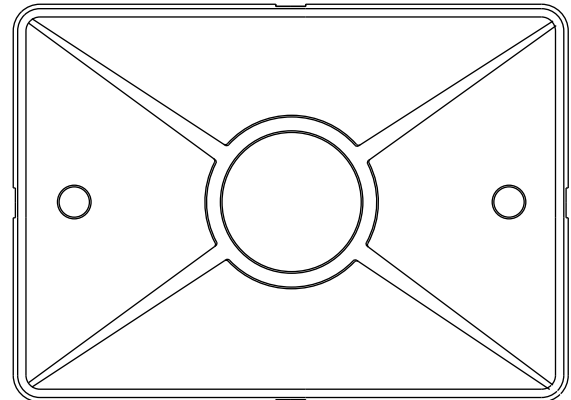

BOTTOM VIEW OF COVER

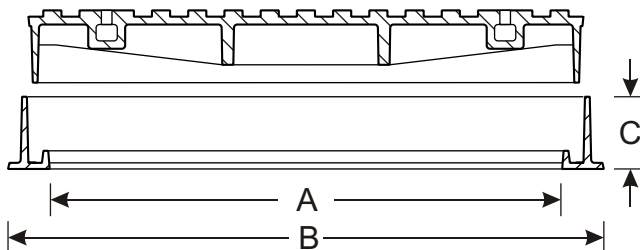

SECTIONAL VIEW OF COVER & FRAME

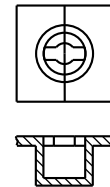

KEY-HOLE SECTION

Sr. No.	B.S. Ref.	Clear Opening of frame mm. A x A	Over Base of frame mm. B x B	Height of frame mm. C	Weight (Kgs.)	TYPE
50	MC1 60/45	600 X 450	700 X 550	42	32 Kgs	Single Seal Solid Top Cover & Frame L/D
51	MC2 60/45	600 X 450	710 X 560	42	50 Kgs	Double Seal Solid Top Cover & Frame L/D

drawn by : H. Vyas

date : 01/01/2006

approved by : Rosy

date : 01/01/2005

www.starpipelineindia.com

scale : NTS

revision : 007

date : 01/01/2021

## CAST IRON ROUND COVER WITH SQARE & ROUND FRAME

Heavy Duty As Per BS 497/1976  
Test Load : 350KN - Block dia. 300mm.

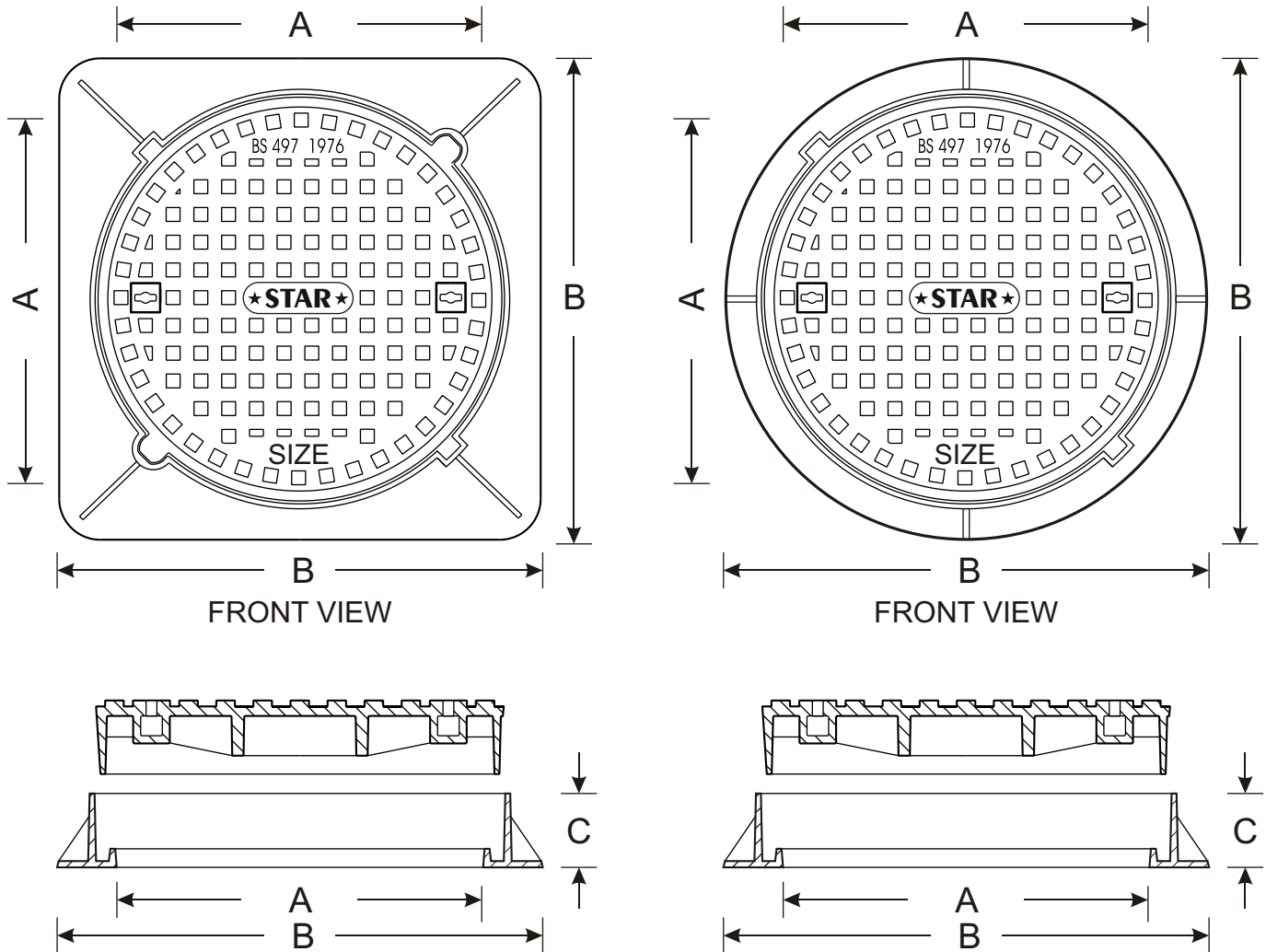

SECTIONAL VIEW OF COVER & FRAME

Sr. No.	B.S. Ref.	Clear Opening of frame mm. A x A	Over Base of frame mm. B x B	Height of frame mm. C	Weight (Kgs.)	TYPE
41	MA - 60	600 Ø	780 X 780	100	150 Kgs	Round Cover & Squre Frame H/D Gr. A
42	MA - 60	600 Ø	785 X 785	100	175 Kgs	Round Cover & Squre Frame H/D Gr. A
43	MA - 60	600 Ø	800 X 800	100	190 Kgs	Round Cover & Squre Frame H/D Gr. A
44	-	600 Ø	825 X 825	125	210 Kgs	Round Cover & Squre Frame H/D Gr. A
45	-	600 Ø	830 X 830	150	250 Kgs	Round Cover & Squre Frame H/D Gr. A
46	-	750 Ø	925 X 925	175	225 Kgs	Round Cover & Squre Frame H/D Gr. A
47	-	750 Ø	950 X 950	175	260 Kgs	Round Cover & Squre Frame H/D Gr. A
48	-	800 Ø	950 X 950	180	250 Kgs	Round Cover & Squre Frame H/D Gr. A
49	-	800 Ø	1000 X 1000	180	300 Kgs	Round Cover & Squre Frame H/D Gr. A

drawn by : H. Vyas

date : 01/01/2006

approved by : Rosy

date : 01/01/2005

www.starpipelineindia.com

scale : NTS

revision : 007

date : 01/01/2021

## Romanian type Cast Iron square Manhole Frame & Cover

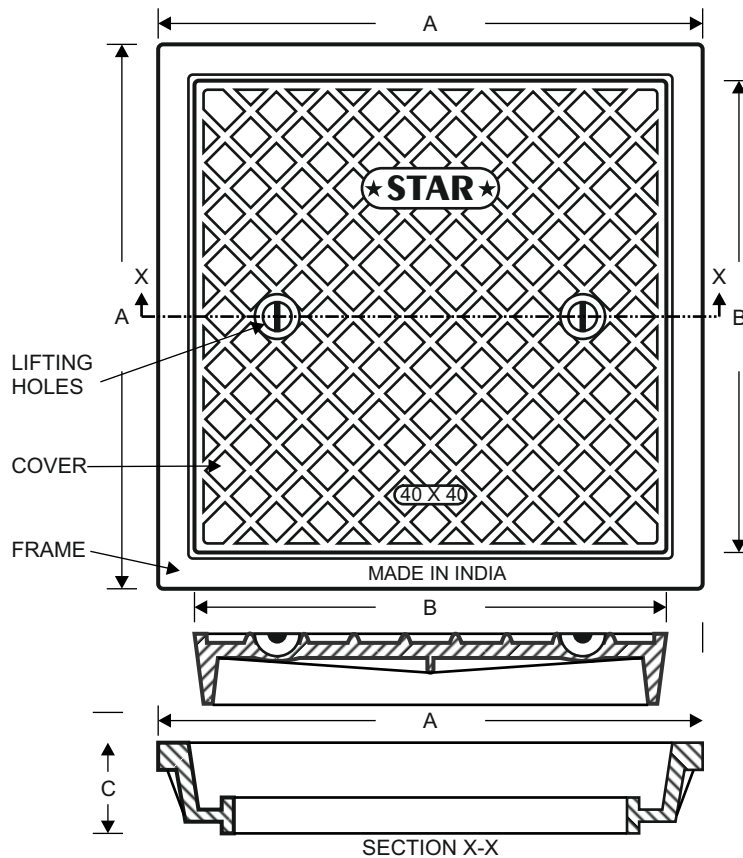

Cast No.	Frame size (cms.) A X A	Weight (Kgs.)		Cover size (cms.) B X B
		Min.	Max.	
01	30 x 30	4.5	5.0	22 x 22
02	40 x 40	7.5	8.0	30 x 30
03	45 x 45	9.5	10.0	35 x 35
04	50 x 50	11.0	12.0	40 x 40
05	50 x 50	20.0	22.0	40 x 40
06	50 x 50	25.0	27.0	40 x 40
07	55 x 55	13.0	14.0	45 x 45
08	60 x 60	16.0	18.0	48 x 48
09	60 x 60	24.0	26.0	48 x 48
10	60 x 60	30.0	32.0	48 x 48
11	60 x 60	60.0	63.0	48 x 48
12	70 x 70	25.0	28.0	55 x 55
13	70 x 70	40.0	43.0	55 x 55
14	70 x 70	70.0	73.0	55 x 55
15	80 x 80	40.0	45.0	70 x 70
16	80 x 80	60.0	65.0	70 x 70
17	80 x 80	80.0	85.0	70 x 70
18	90 x 90	80.0	100.0	80 x 80
19	100 x 100	90.0	100.0	90 x 90
20	100 x 100	110.0	120.0	90 x 90

drawn by : H. Vyas

date : 01/01/2006

approved by : Rosy

date : 01/01/2005

www.starpipelineindia.com

scale : NTS

revision : 007

date : 01/01/2021



## DUCTILE IRON Solid Top Double Seal Manhole Cover & Frame GRP Plate Sealing as per BS EN-124/1994

Light, Medium & Heavy D uty Class B125, C250 & D400

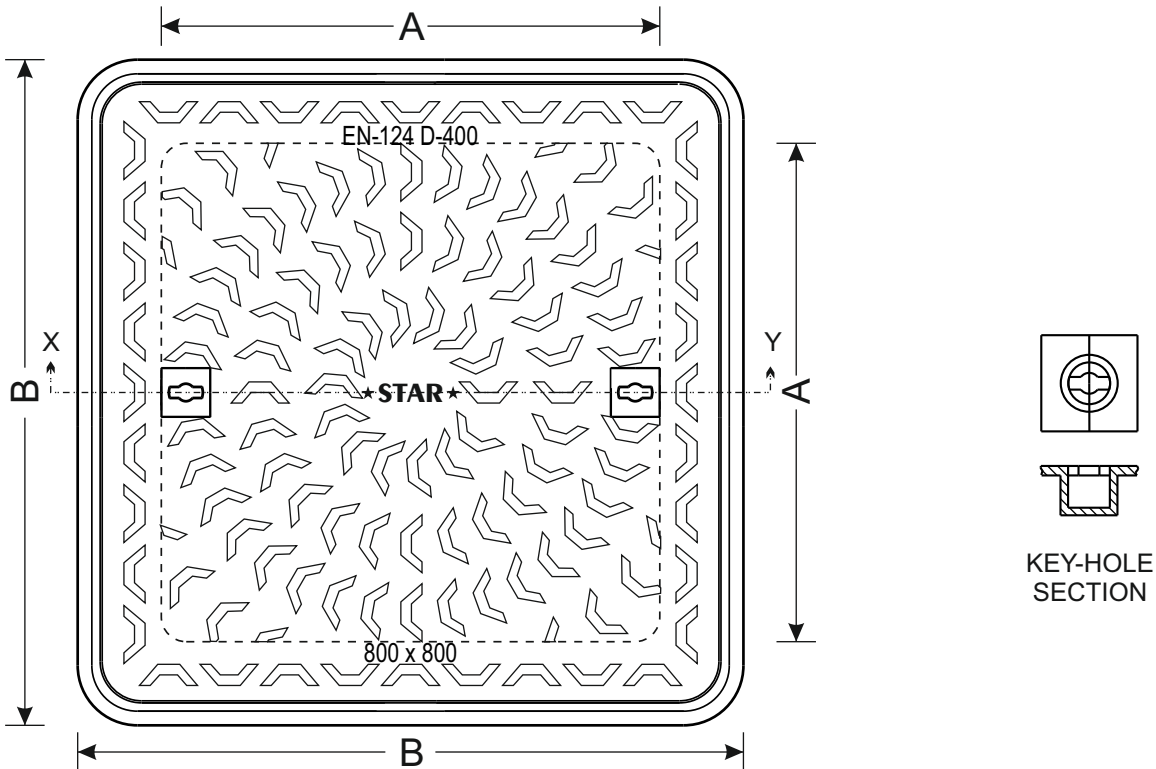

TOPVIEW OF COVER

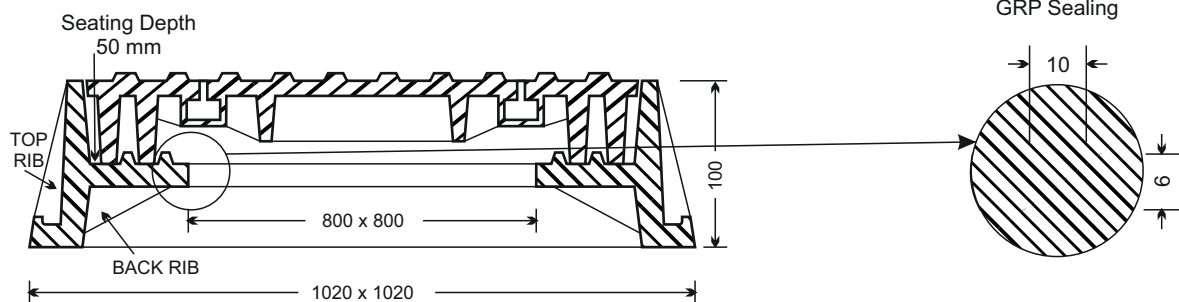

SECTIONALVIEW OF COVER & FRAME

Sr.No.	Class	Clear opening of Frame (mm.) A x A	Over base of Frame (mm.) B x B	Height (mm.) C	Weight each (Kgs.)	TYPE
01	D-400	800 X 800	1020 X 1020	100	147 Kgs	Double Seal Solid Top Cover & Frame with GRP Sealing D-400

drawn by : H. Vyas

date : 01/01/2006

approved by : Rosy

date : 01/01/2005

www.starpipelineindia.com

scale : NTS

revision : 007

date : 01/01/2021